

ROOM TEMP.:  
Dry  
 INTERIOR AREA:  
97 sq. ft.  
 HORSEPOWER:  
—  
 REFRIGERANT:  
—  
 ELEC. SUPPLY  
115  
 PHASE:  
Single  
 CYCLE:  
60 hz.  
 AMPERAGE:  
MCA

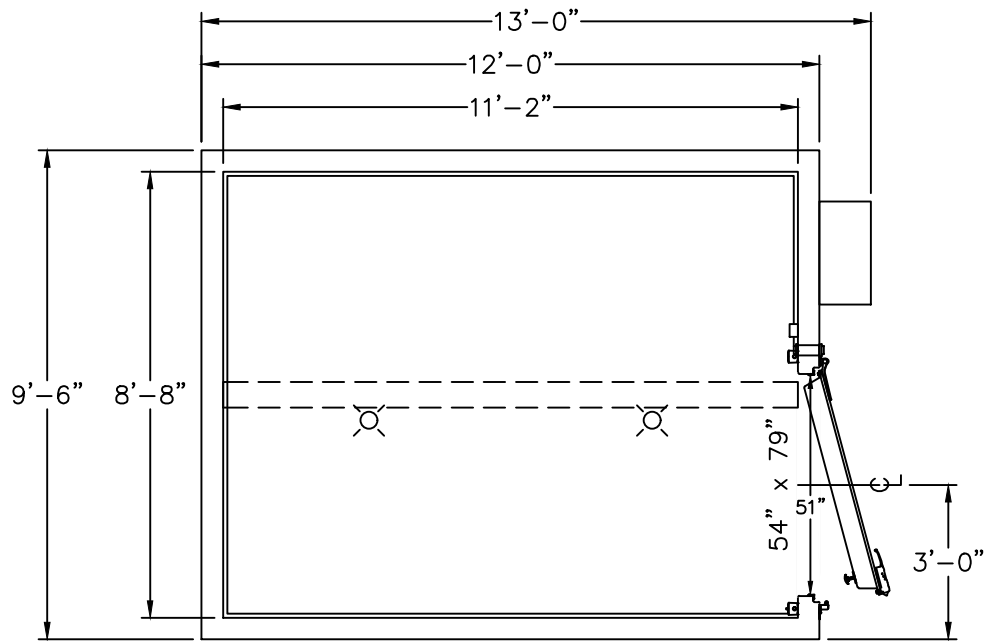

PLAN VIEW

CLASS 1 DIVISION 1 INTERIOR

- 5" WALLS
- 6" CROWNED ROOF
- 1 1/4" PALLET JACK DUTY FLOOR
- PALLET BUMPER GUARD
- SPRING HINGES
- KICK PLATES
- AMEREX FIRE SUPPRESSION SYSTEM
- CEILING REINFORCEMENT

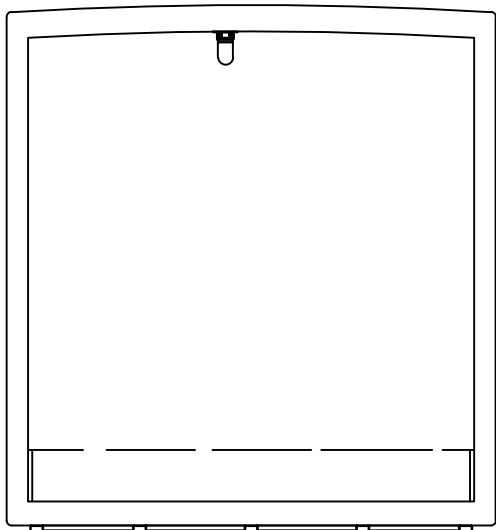

SECTION VIEW

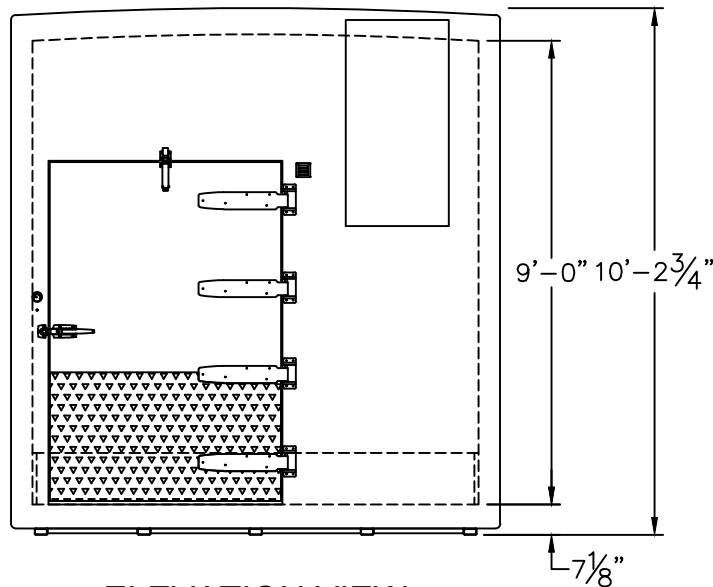

ELEVATION VIEW

**DRAWING APPROVAL**

PLEASE INDICATE YOUR APPROVAL OF THIS DESIGN, THE DIMENSIONS, DOOR LOCATION/SWING, ELECTRICAL REQUIREMENTS, AND EQUIPMENT LOCATIONS BY SIGNING BELOW AND RETURNING TO POLAR KING.

DATE:	BY:
-------	-----

A19039002

DRAWN BY: MJR	MODEL NO.: *1012	SCALE: 1/4"=1'-0"	DATE: 5/11/22
------------------	---------------------	----------------------	------------------

DRAWING NAME: \_\_\_\_\_

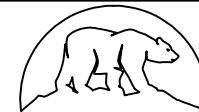

**POLAR KING**  
INTERNATIONAL, INC.

FORT WAYNE, INDIANA 1-800-752-7178

THE REFRIGERATION SYSTEM SHOWN IS DESIGNED TO MAINTAIN INDICATED TEMPERATURE IF PRODUCT ENTERS WITHIN 10°F OF FINAL HOLDING TEMPERATURE. PLEASE CONTACT YOUR SALES REP IF INCOMING PRODUCT WILL BE ENTERING AT HIGHER TEMPERATURES. REFRIGERATION DESIGN IS SUBJECT TO CHANGE FOR IMPROVEMENTS.