

ROOM TEMP.:  
0°F  
 INTERIOR AREA:  
38 sq. ft.  
 HORSEPOWER:  
3/4 hp.  
 REFRIGERANT:  
R-404A  
 ELEC. SUPPLY  
115V  
 PHASE:  
Single  
 CYCLE:  
60 hz.  
 AMPERAGE:  
19.2 MCA

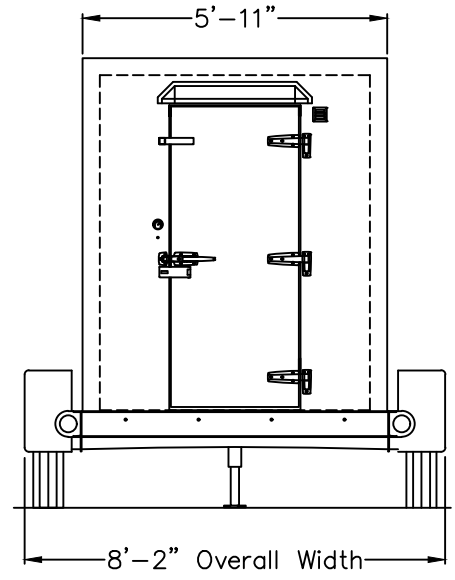
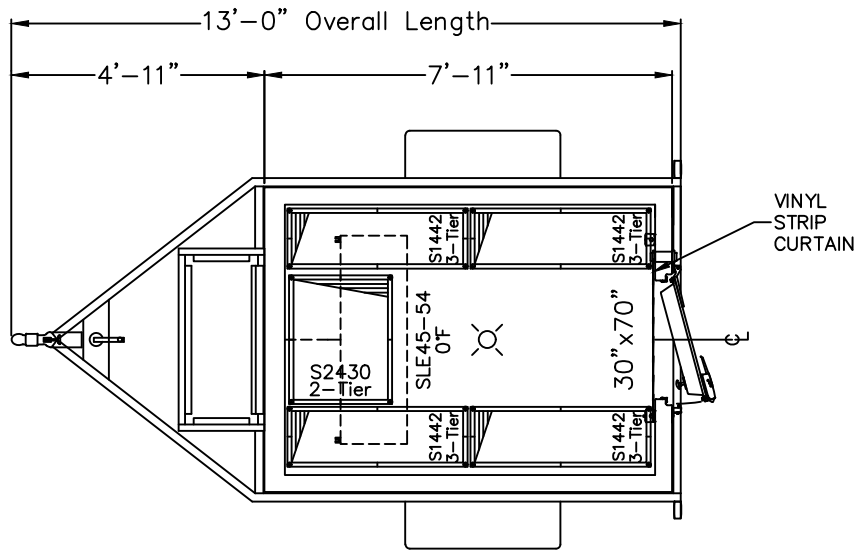

EJAL-A075-CAA

**PLAN VIEW**

INSIDE DIMENSIONS:  
 5'-3" WIDE  
 7'-3" LONG  
 6'-6" HIGH

MAX LOADED WEIGHT: 3,500 LB  
 TRAILER EMPTY WEIGHT: 2,100 LB  
 MAX DISTRIBUTED LOAD: 1,400 LB

- 4" WALL INSULATION
- 4" FLAT ROOF INSULATION
- 1/2" STANDARD DUTY FLOORING
- VINYL STRIP CURTAIN
- GENERATOR PLATFORM
- SPARE TIRE & WHEEL ASSEMBLY
- SHELVING PACKAGE

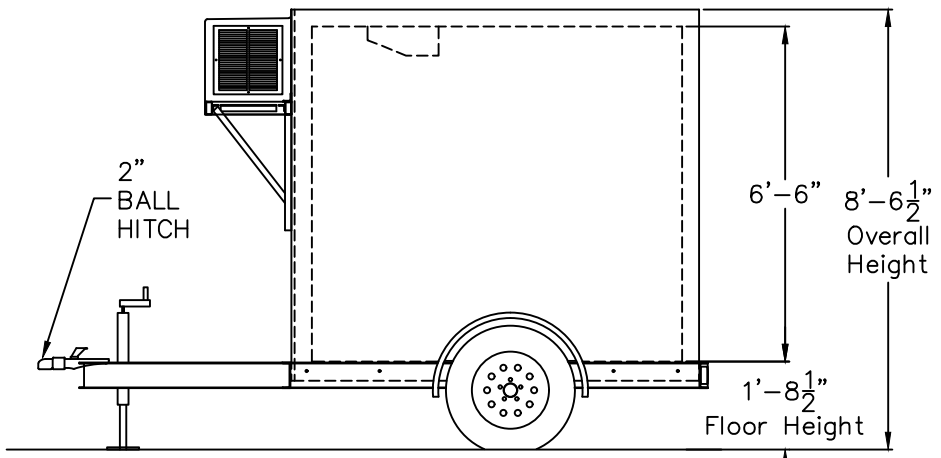

**ELEVATION VIEW**

**DRAWING APPROVAL**

PLEASE INDICATE YOUR APPROVAL OF THIS DESIGN, THE DIMENSIONS, DOOR LOCATION/SWING, ELECTRICAL REQUIREMENTS, AND EQUIPMENT LOCATIONS BY SIGNING BELOW AND RETURNING TO POLAR KING.

DATE: \_\_\_\_\_ BY: \_\_\_\_\_

A17028069

DRAWN BY: BJS	MODEL NO.: M68T	SCALE: 1/4"=1'-0"	DATE: 7-27-16
------------------	--------------------	----------------------	------------------

DRAWING NAME: A117028069



FORT WAYNE, INDIANA 1-800-752-7178

THE REFRIGERATION SYSTEM SHOWN IS DESIGNED TO MAINTAIN INDICATED TEMPERATURE IF PRODUCT ENTERS WITHIN 10°F OF FINAL HOLDING TEMPERATURE. PLEASE CONTACT YOUR SALES REP IF INCOMING PRODUCT WILL BE ENTERING AT HIGHER TEMPERATURES. REFRIGERATION DESIGN IS SUBJECT TO CHANGE FOR IMPROVEMENTS.